

FVF

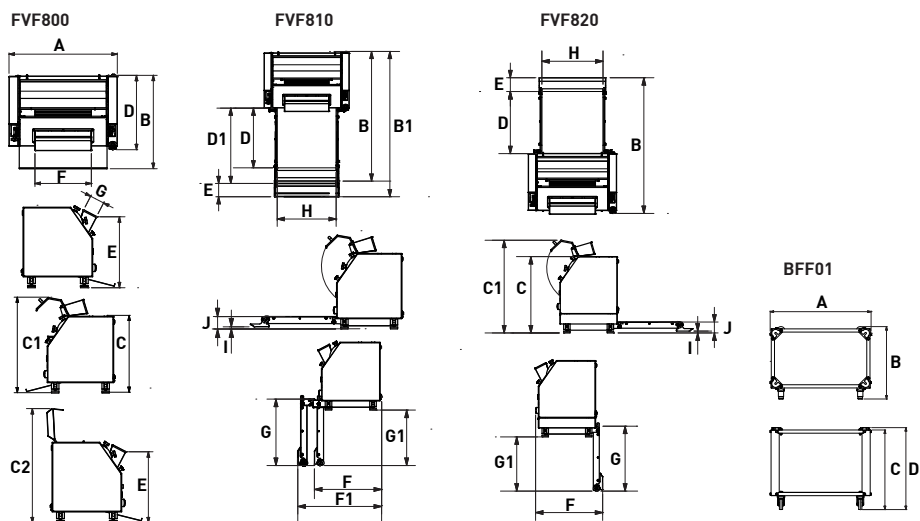

MODELADORA DE BAGUETES



CC_017-4

FVF

PESO POR PEÇA (g)-(lb) MIN. 50 (0,11) MAX. 1200 (2,65)

PRODUÇÃO
un/min MIN. 1 MAX. 20
un/h MIN. 60 MAX. 1200

POTÊNCIA (kW)-(hp) 230V.3ph.60Hz 1,1 (1,5)

Outras voltagens e certificações: sob consulta

OPÇÕES

	FVF800	FVF800+TS810	FVF800+TS820	BFF01
PESO LÍQUIDO (kg)-(lb)	202 (445,33)	230 (507,06)	230 (507,06)	30 (66,14)
A	960 (37 13/16)	960 (37 13/16)	960 (37 13/16)	945 (37 3/16)
B	830 (32 11/16)	1465 (57 11/16)	1480 (58 1/4)	680 (26 3/4)
B'	-	1640 (64 9/16)	-	-
C	720 (28 3/8)	725 (28 9/16)	835 (32 7/8)	745 (29 5/16)
C'	1030 (40 9/16)	1030 (40 9/16)	1140 (44 7/8)	-
D	660 (26)	675 (26 9/16)	675 (26 9/16)	770 (30 5/16)
D'	-	850 (33 7/16)	-	-
E	535 (21 1/16)	150 (5 7/8)	150 (5 7/8)	-
F	500 (19 11/16)	715 (28 1/8)	730 (28 3/4)	-
F'	-	890 (35 1/16)	-	-
G	130 (5 1/8)	710 (27 15/16)	710 (27 15/16)	-
G'	-	590 (23 1/4)	590 (23 1/4)	-
H	-	665 (26 3/16)	665 (26 3/16)	-
I	-	20 (13/16)	20 (13/16)	-
J	-	120 (4 3/4)	120 (4 3/4)	-

DIMENSÕES (mm)-(in)

EQUIPAMENTO DE SÉRIE

ESTRUTURA EM AÇO INOXIDÁVEL

MESA DE SAÍDA FRONTAL, 700X1000MM

MESA DE SAÍDA TRASEIRA, 700X1000MM

OPÇÕES

ESTRUTURA DE APOIO COM RODAS, 945X600X770MM

TOL08 - TOLVA BAIXA, 120MM ZONA DE RISCO, AÇO INOXIDÁVEL

UL-NSF

CE